

HOME VENTILATION WITH HEAT RECOVERY

# Flush-mount installation kit with plastering trim (solid construction) M-WRG-M/MB

for flush-mounting  
M-WRG-S... ventilation units

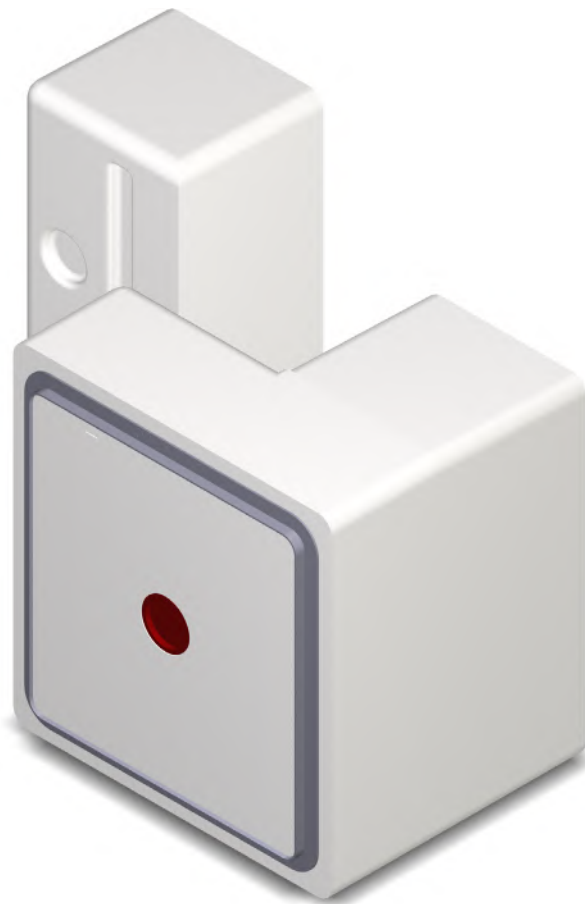

INSTALLATION MANUAL

Part no. 5300-01-01 Week 45/2022 EN



# Contents

<b>1</b>	<b>Introduction</b> .....	<b>4</b>
1.1	Notes on this installation manual .....	4
1.2	Description .....	4
1.3	Target group .....	5
1.4	Nameplates .....	5
1.5	Storage .....	5
1.6	Revision index .....	5
1.7	Explanation of the symbols used .....	6
1.8	Supplementary documents .....	6
<b>2</b>	<b>Safety instructions</b> .....	<b>7</b>
2.1	Hazard classification .....	7
2.2	Notes on using the ventilation units safely .....	7
2.2.1	Fire protection .....	7
2.2.2	Operation with fireplaces .....	7
2.2.3	Installation in wet areas .....	8
2.2.4	Build-up of icicles and ice patches at low temperatures .....	8
2.2.5	Starting and using the ventilation unit .....	8
2.3	Notes on using the ventilation units .....	8
2.4	Note on use in conjunction with room air conditioners .....	9
2.5	Intended use .....	9
<b>3</b>	<b>Planning notes</b> .....	<b>10</b>
3.1	Requirements for the installation wall .....	10
3.2	Positioning the ventilation unit indoors .....	10
3.3	Unrestricted access to the ventilation unit .....	12
3.4	Retrospectively flush-mounting the installation kit .....	12
3.5	Electrical connection .....	12
<b>4</b>	<b>Warranty and liability</b> .....	<b>13</b>
4.1	Warranty .....	13
4.2	Liability .....	13
<b>5</b>	<b>Items supplied</b> .....	<b>14</b>
5.1	Installation kit M-WRG-M/MB, part no. 5051 .....	14
5.2	Options .....	14
5.3	Installation materials required .....	14
<b>6</b>	<b>Dimensions of the installation kit</b> .....	<b>15</b>
<b>7</b>	<b>Tools and equipment required</b> .....	<b>16</b>
<b>8</b>	<b>General installation instructions</b> .....	<b>16</b>

<b>9</b>	<b>Installing the installation kit</b>	<b>17</b>
9.1	Breaking through the wall	17
9.1.1	Planning the wall breakthrough for new builds	17
9.1.2	Breaking through an existing wall	18
9.2	Chasing out channels for connecting cables	18
9.3	Running the mains and control cables	19
9.3.1	Cable types	20
9.3.2	External control input	20
9.4	Inserting the wall box	21
9.5	Inserting the cardboard insert and plaster cover	22
9.6	Fixing the wall box	22
9.7	Filling gaps around the wall box with foam	23
9.8	Condensate drain on the exhaust air pipe	24
9.9	Plastering the installation kit on the inside	25
9.10	Aligning the wall box on the outside before plastering	26
9.10.1	If the solid wall is less than 36.5 cm thick	26
9.10.2	If the solid wall is more than 36.5 cm thick	26
9.11	Plastering the installation kit on the outside	27
9.12	Preparing the installation kit for connecting the ventilation pipes	28
9.13	Cutting ventilation pipes to length	28
9.14	Inserting and fixing the ventilation pipes	29
9.15	Sealing ventilation pipes on external wall	29
9.16	Attaching the outer wall terminal	30
<b>10</b>	<b>Installing the ventilation unit</b>	<b>30</b>

# 1 Introduction

## 1.1 Notes on this installation manual



This installation manual contains important information that should be followed when installing the M-WRG-M/MB installation kit for the M-WRG ventilation units.

- ▶ Read all the instructions carefully before installing the kit to avoid possible risks and mistakes.
- ▶ When assembly is complete, give these instructions to the home owner, caretaker or property manager.
- ▶ These instructions are part of the product. Keep the instructions in a safe place for future reference.

### **⚠ WARNING**

- ▶ Follow ALL danger and warning instructions and notes on precautionary measures.
- ▶ Read sections “2 Safety instructions” on page 7 and “3 Planning notes” on page 10 carefully.

## 1.2 Description

This manual describes how to flush-mount the M-WRG-M/MB installation kit (item 1 in Fig. 1) in solid walls. In new builds, if a complete wall aperture is planned for the installation kit or if a complete wall breakthrough is planned for a retrofit, the optional filler piece M-WRG-M/Fü (item 2 in Fig. 1) can be used to pack out the wall.

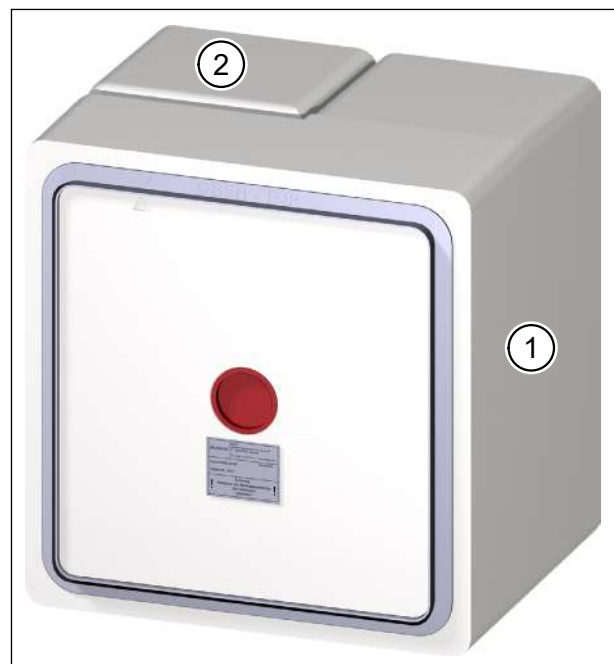

Fig. 1: Installation kit M-WRG-M/MB with optional filler piece M-WRG-M/Fü

### 1.3 Target group

The activities described in this manual must only be carried out by specialised personnel with the following qualifications:

- Training in the installation and commissioning of electrical devices
- Training in electrical hazards and the local safety requirements
- Knowledge of the relevant standards and directives
- Knowledge and observance of this document and all the safety instructions

### 1.4 Nameplates

The nameplates are attached in two places:

- on the plaster cover (item 1 in Fig. 2)
- beside the cable inlet for the mains cable (item 1 in Fig. 3)

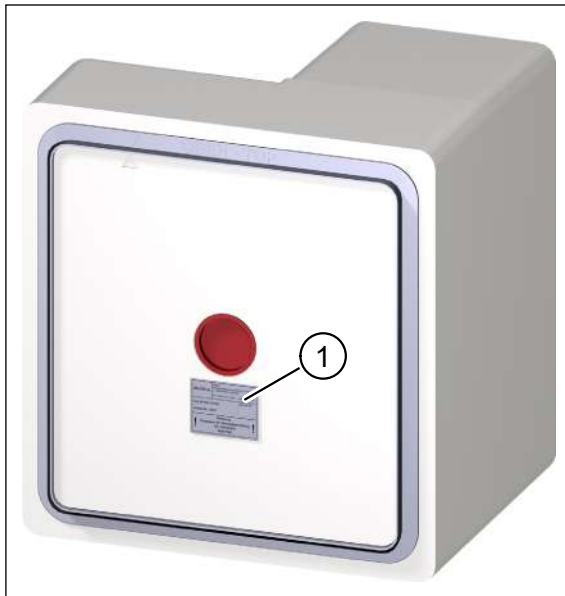

Fig. 2: Nameplate on the plaster cover



Fig. 3: Nameplate beside cable inlet

### 1.5 Storage

Store the installation kit in its original packaging in a dry place where the temperature ranges between 0 °C and +40 °C.

### 1.6 Revision index

Edition	Manual	Date
4 <sup>th</sup> edition	Installation manual for flush-mount installation kit with plastering trim (solid construction) M-WRG-M/MB	Week 45/2022 EN

## 1.7 Explanation of the symbols used

- ▶ This symbol indicates an action to be taken.
- This symbol indicates a list.

## 1.8 Supplementary documents

Manual	Part no.
Installation manual for M-WRG-S... ventilation units	5253-01
Installation manual for outer wall terminals M-WRG-II ES..., M-WRG-ES..., M-WRG-II KSR...	744005EN
Installation manual for window reveal installation kit	5300-60-01
Operating instructions for M-WRG-S ventilation unit	5302-00-01

Table 1: Supplementary documents

## 2 Safety instructions

These instructions contain notes that you must follow for your own personal safety and to avoid injury and damage to property. They are highlighted by warning triangles and are shown as follows according to the level of danger.

### 2.1 Hazard classification

#### **DANGER**

The signal word designates a hazard with a **high** degree of risk which, if it is not avoided, will result in death or severe injury.

#### **WARNING**

The signal word designates a hazard with a **medium** degree of risk which, if it is not avoided, will result in death or severe injury.

#### **CAUTION**

The signal word designates a hazard with a **low** degree of risk which, if it is not avoided, could result in minor or moderate injury.

#### **NOTICE**

A note as used in this manual contains important information about the product or about a part of the manual to which particular attention should be paid.

### 2.2 Notes on using the ventilation units safely

#### 2.2.1 Fire protection

Follow the generally applicable fire safety requirements when planning and installing the unit.

#### 2.2.2 Operation with fireplaces

- When M-WRG ventilation units are used in conjunction with fireplaces, an additional safety device (underpressure or differential pressure monitor) is needed to monitor operation and to switch off the (230 V) power supply to the units when necessary.
- Follow the requirements of the German Fire Code (FeuVo) when planning and installing the unit.
- Contact the local chimney sweep before the end of the planning phase.
- Have the chimney sweep approve the operation of the ventilation unit.
- Correct use of a ventilation system set up with the decentralised ventilation unit requires the possibility of shutting off combustion air pipes and flue systems for solid fuel fireplaces during periods in which the fireplaces are not in use.

### 2.2.3 Installation in wet areas

The following rules from DIN VDE 0100-701/702 (IEC 60364-7-701) apply to installation of M-WRG ventilation units in wet areas:

- Protection zone 0: The unit must NOT be installed in this area.
- Protection zone 1: The unit must only be installed with the “integrated into wall” U<sup>2</sup> variant. The extract and supply air valves must be installed in the top part of the wall or in the ceiling.
- Protection zone 2: The unit may be installed in this area if the mains switch is covered with a protective cap. The protective cap must be installed at the factory.
  - ▶ You will need to include the mains switch protective cap (M-WRG-SN, part no. 5430) when you order the ventilation unit.
- Other zone: The unit may be installed in this area.

Country-specific standards/regulations on observing the protection zones for installation in rooms with bathtub or shower must also be followed.

### 2.2.4 Build-up of icicles and ice patches at low temperatures

The heat recovery process in our ventilation units causes condensation. This condensation is dissipated to the outside via the exhaust air pipe. When external temperatures drop below 0 °C this can cause a build-up of icicles at the outer wall terminals and ice patches on the ground.

For this reason, the position of the units and arrangement of the outer wall terminals should be selected to eliminate any risk to people and property.

If such risks cannot be excluded, a condensate connection should be provided (see section 9.8 on page 24).

### 2.2.5 Starting and using the ventilation unit

- Do not start up the ventilation unit until it is fully installed.
- Always operate the ventilation unit with the air filters fitted.
- Always make sure that the cover is closed and locked in place before using the ventilation unit.
- Please note that the ventilation unit must not be used without the outer wall terminal for safety reasons.

### 2.3 Notes on using the ventilation units

- This unit may be used by children from 8 years old and by persons of restricted physical, sensory or mental abilities or persons lacking experience and knowledge if they are supervised or have been instructed in how to use the unit safely and understand the associated hazards. Do not allow children to play with the unit. Cleaning and user maintenance must not be carried out by children unless they are supervised.
  - ▶ Follow the regulations applicable in your country concerning the age from which people may be permitted to operate the ventilation unit.



- The ventilation unit must always be freely accessible for operation and maintenance.
  - ▶ Make sure that the ventilation unit is not covered or obstructed when the room is subsequently decorated and furnished, otherwise it cannot be operated and it will not be possible to replace the air filters. You should therefore maintain a clearance of at least 15 cm in front of the ventilation unit cover.
  - ▶ Make sure that the supply and extract air openings are not covered when the room is subsequently decorated and furnished, otherwise the ventilation unit's functions may be impaired.

## 2.4 Note on use in conjunction with room air conditioners

Condensation may form in the ventilation unit if the outdoor air temperature and humidity are high, but the room temperature is cool.

For the M-WRG ventilation units, the room temperature should therefore be set to no more than 8 °C below the external temperature.

M-WRG ventilation units and room air conditioners can be combined very well.

## 2.5 Intended use

- The ventilation unit is designed to ventilate living spaces and rooms used for quasi-residential purposes. It can also be installed in offices, surgeries, etc. The ventilation unit is installed in a perpendicular position in the external wall. Any different or more extensive usage will be regarded as contrary to the intended use.
- The intended use also includes compliance with all the notes in the operating instructions.
- The ventilation unit must not be operated without air filters or outer wall terminal.
- The ventilation unit is intended for use in rooms with normal room air humidity levels of approx. 40 % to 70 % RH. It must not be installed in rooms in which the relative humidity during operation constantly exceeds 80 %.
- The ventilation unit's functions may be impaired or the unit may be damaged in rooms with a lot of dust (e.g. model-making) or corrosive gas emissions (e.g. blueprint shop, cleaning).
- For any use contrary to the intended use, Meltem Wärmerückgewinnung GmbH & Co. KG shall accept no liability for any damage that may occur and offers no warranty that the ventilation unit will work perfectly and correctly.

## 3 Planning notes

### 3.1 Requirements for the installation wall

The installation kit can be installed in solid walls that are at least 20 cm thick (including internal plaster, external render and insulation).

- For wall structures that are 60 cm thick or more, you will need 100 cm long outdoor and exhaust air pipes (M-WRG-LR 100, part no. 5580).

#### NOTICE

The installation kit fixes the ventilation pipes with a 2° fall to the external wall.

- If the unplastered wall is thin (24 cm or less), do not cut off the installation kit flush with the unplastered wall (see section 9.10 on page 26). Allow the kit to protrude into the external thermal insulation composite system (ETICS) as this is the only way to allow the ventilation pipes to pass far enough through and so be fixed in place.
- When fitting the ETICS, make sure that the ventilation pipes maintain their 2° fall.

### 3.2 Positioning the ventilation unit indoors

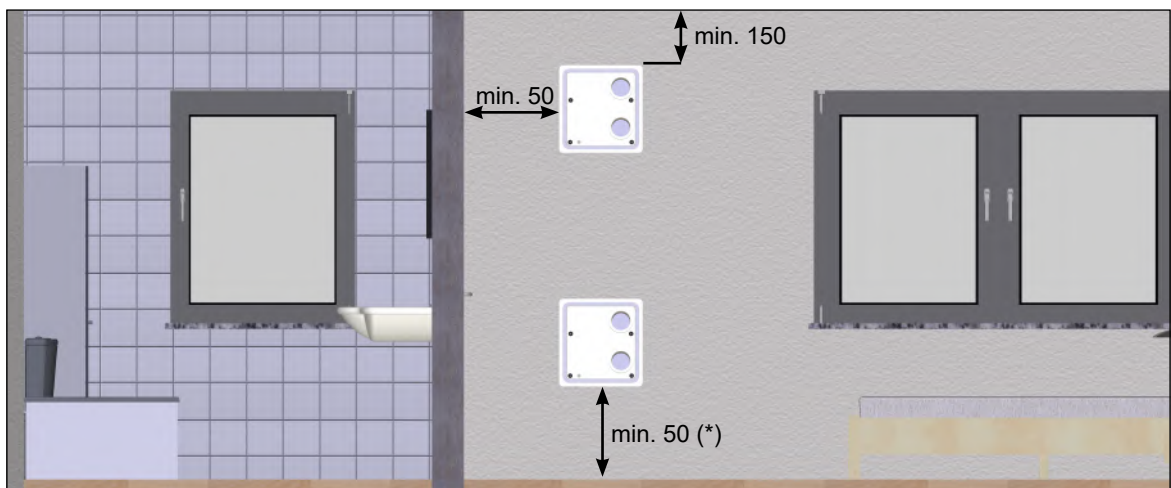

Fig. 4: Minimum distances and options for positioning the M-WRG-M/MB installation kit, dimensions in millimetres

- (\*) If a condensate connection (see section 9.8 on page 24) is used, the minimum dimensions must be adapted to suit the local conditions. This applies, in particular, if condensate is drained inwards, e.g. via a greywater outlet.

The ventilation unit must be installed indoors in a perpendicular position on an external wall.

- The flush-mount installation (wall box) kit must be installed so that the openings for extract air and supply air point up.
- For a standard room height of 2.50 m, the best effect for air exchange is achieved if the top edge of the unit with the supply and extract air openings is roughly 300 mm below the ceiling.

- ▶ Maintain the following minimum distances (see Fig. 4 and Fig. 5):
  - The distance between the top edge of the wall box and the ceiling must be at least 150 mm to prevent an air short circuit.
  - The distance between the side and bottom edges of the wall box and adjacent surfaces should be at least 50 mm (exception: if a condensate connection is used, see (\*) in Fig. 4 on page 10). The ventilation unit will be easier to operate if this minimum distance is maintained. It also allows the air filter to be replaced without obstruction.
  - The lateral distance between two wall boxes must not be less than 200 mm to prevent an air short circuit between the ventilation units.

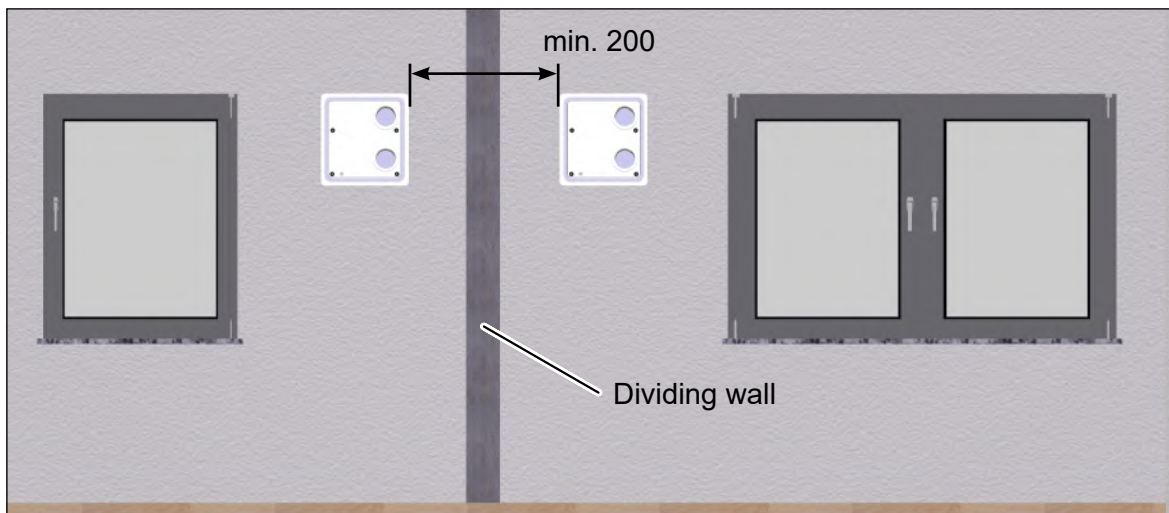

Fig. 5: Lateral minimum distance between two wall boxes, dimensions in millimetres

- ▶ If the room height is greater than 2.50 m, position the ventilation unit so that the unit can be operated and filters can be maintained unaided (without steps, ladders, etc.). Alternatively you can order a ventilation unit that can be operated externally.

#### NOTICE

Follow the notes in Table 2 on page 20 when planning the unit. This contains information about the types of mains and control cable for each ventilation unit and the recommended operating options.

### 3.3 Unrestricted access to the ventilation unit

The ventilation unit must always be freely accessible for operation and maintenance.

- ▶ Make sure that the ventilation unit is not covered or obstructed when the room is subsequently decorated and furnished, otherwise it cannot be operated and it will not be possible to replace the air filters. You should therefore maintain a clearance of at least 15 cm in front of the ventilation unit cover.
- ▶ Make sure that the supply and extract air openings are not covered when the room is subsequently decorated and furnished, otherwise the ventilation unit's functions may be impaired.

### 3.4 Retrospectively flush-mounting the installation kit

#### **WARNING**

##### **Danger from emerging gas or electric shock**

- ▶ Make sure that there are no supply lines in the vicinity of the wall breakthrough (e.g. power, gas or water).
- ▶ Make sure that the wall breakthrough does not affect the local static loading requirements.
- ▶ Fit a lintel if necessary.

### 3.5 Electrical connection

The working voltage range of the ventilation unit is between 85 V AC and 265 V AC / 50 - 60 Hz.

#### **NOTICE**

If the ventilation unit is not equipped with a mains connection cable and plug or other means of disconnecting from the mains supply that has, at each pole, a contact opening width that conforms to the conditions of overvoltage category III for complete separation, then such an isolating unit (e.g. circuit breaker) must be integrated into the permanently installed electrical system in accordance with the installation regulations. The isolating unit must be identified as such and easy to access.

## **4 Warranty and liability**

### **4.1 Warranty**

The following cases shall invalidate the warranty:

- The installation kit was not installed as described in the installation manual.
- The ventilation unit was not installed as described in the installation manual.
- The ventilation unit was flush-mounted without using a flush-mount installation kit.
- Genuine parts/genuine air filters were not replaced with genuine parts.
- Unapproved changes were made to the installation kit or ventilation unit.
- Repairs were not carried out by Meltem or by an authorised specialist company.
- The ventilation unit was operated without air filters and outer wall terminals.
- The warranty does not cover wearing parts such as air filters.

### **4.2 Liability**

The manufacturer's liability shall not apply in the following cases:

- The installation kit was not installed as described in the installation manual.
- The ventilation unit was not installed as described in the installation manual.
- The ventilation unit was flush-mounted without using a flush-mount installation kit.
- Genuine parts/genuine air filters were not replaced with genuine parts.
- Unapproved changes were made to the installation kit or ventilation unit.
- Repairs were not carried out by Meltem or by an authorised specialist company.
- The ventilation unit was operated without air filters and outer wall terminals.

## 5 Items supplied

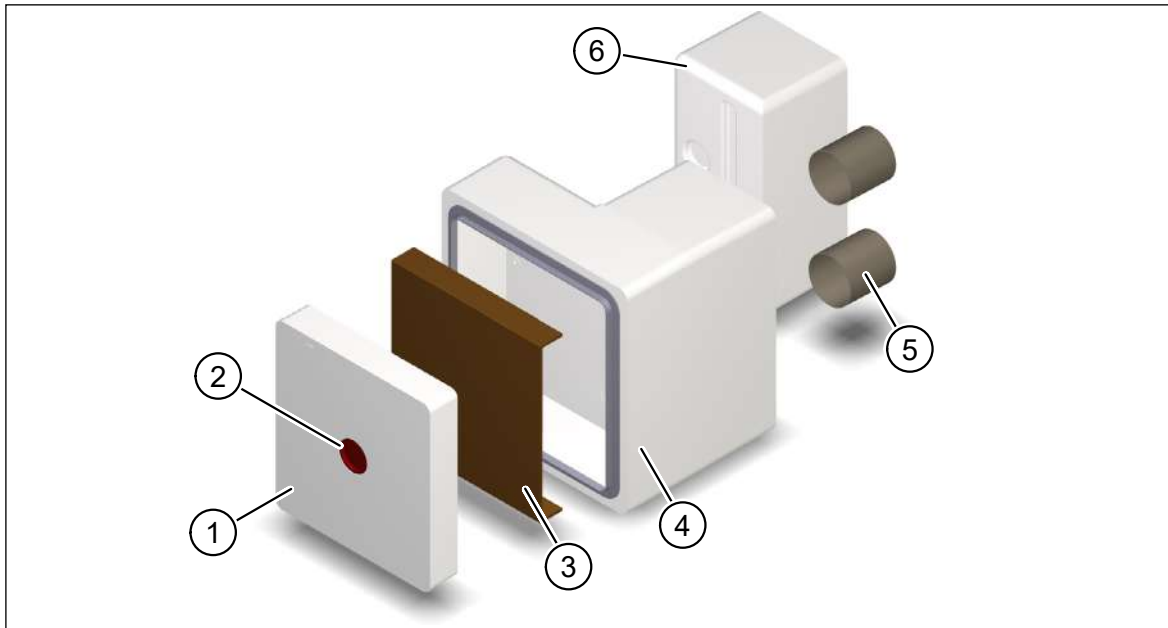

Fig. 6: Items supplied with the installation kit M-WRG-M/MB

### 5.1 Installation kit M-WRG-M/MB, part no. 5051

Item	Description	Quantity
1	Plaster cover for wall box	1 x
2	Signal cover	1 x
3	Cardboard insert	1 x
4	Wall box	1 x
5	Protective sleeve	2 x

### 5.2 Options

Item	Description	Part no.
6	Installation kit filler piece M-WRG-M/Fü	5575-5
-	Plaster scrim M-WRG-PG	5060

### 5.3 Installation materials required

Additional installation materials are needed for flush-mount installation. These must be ordered separately.

Item	Description	Part no.
-	Outdoor air and exhaust air pipe, DN 100, 2 x 0.5 m, M-WRG-LR 50	5574
-	If a condensate connection is used: Outdoor air and exhaust air pipes, DN 100, 2 x 0.5 m, exhaust air pipe with 1/2" male thread condensate connection, M-WRG-II LR 50-KA	735200

## 6 Dimensions of the installation kit

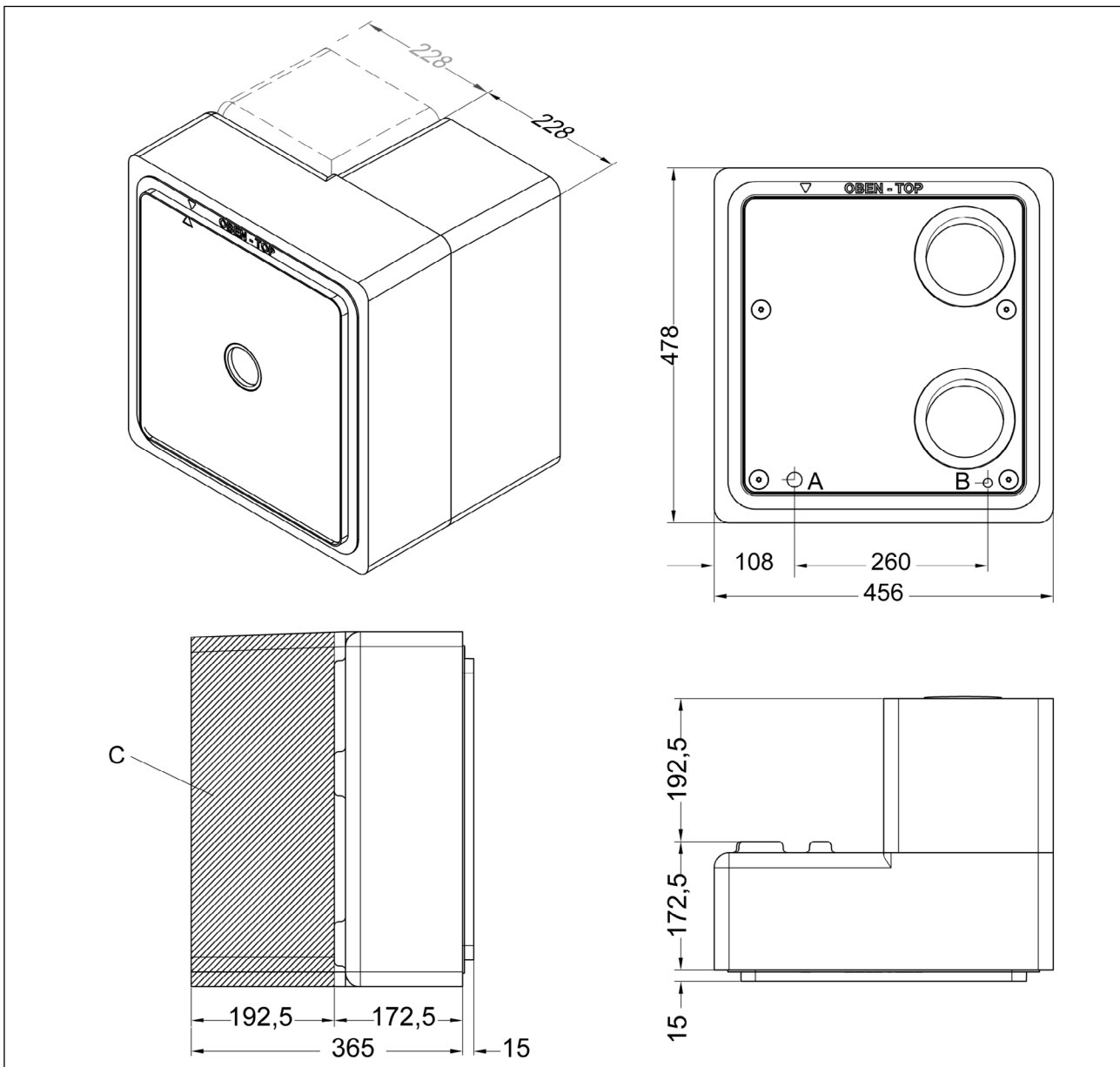

Fig. 7: Installation kit dimensions in millimetres

- A Cable inlet for mains cable
- B Cable inlet for control cable (only needed for certain ventilation units, see Table 2 on page 20)
- C The installation kit can be shortened by 192.5 mm to a minimum length of 172.5 mm (without plastering trim).

### NOTICE

With the M-WRG M-M/MB option, part no. 5045-5-01, the kit can be shortened at the factory to a minimum length of 172.5 mm (without plastering trim). This dimension is subject to manufacturing tolerances.

## 7 Tools and equipment required

- Permanently elastic sealant, solvent-free if applied to polystyrene
- Wedges for fixing the wall box, 8 x  
alternatively use inflatable air cushions, 4 x, e.g. Amo-Bag from Würth, part no. 07156780
- If necessary, wedges for fixing the filler piece, 4 x  
alternatively use inflatable air cushions, 2 x, e.g. Amo-Bag from Würth, part no. 07156780
- Wall chaser
- Expanding foam with abP (national technical test certificate of the DIBt) approval  
("exact gap" foam is recommended)
- Saw for cutting the ventilation pipes to length
- Styrofoam saw
- Spirit level

### NOTICE

If the installation kit is to be retrospectively installed in a solid wall, you will need additional tools to break through the wall.

## 8 General installation instructions

### NOTICE

- The installation must be carried out in accordance with the generally acknowledged rules of technology.
- Connections with adjacent components must be formed to absorb movements between the contact surfaces.
- Seal any connections that are exposed to driving rain with tapes, profiles or sealants such that they offer sufficient protection against the expected conditions.

### WARNING

#### Follow the relevant accident prevention regulations

- ▶ Follow the accident prevention regulations when setting up the installation location.
- ▶ Protect the outside area against falling parts.



## 9 Installing the installation kit

### 9.1 Breaking through the wall

The wall breakthrough can either be included when planning a new build or subsequently made in the solid wall.

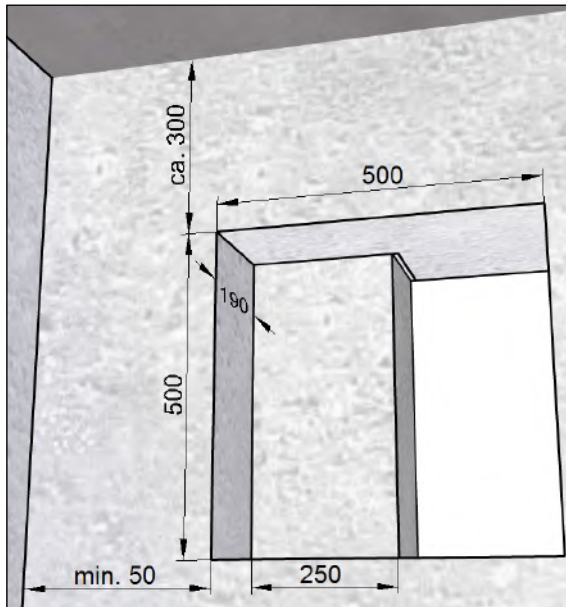

Fig. 8: Wall breakthrough for installation kit **without** filler piece, dimensions in millimetres

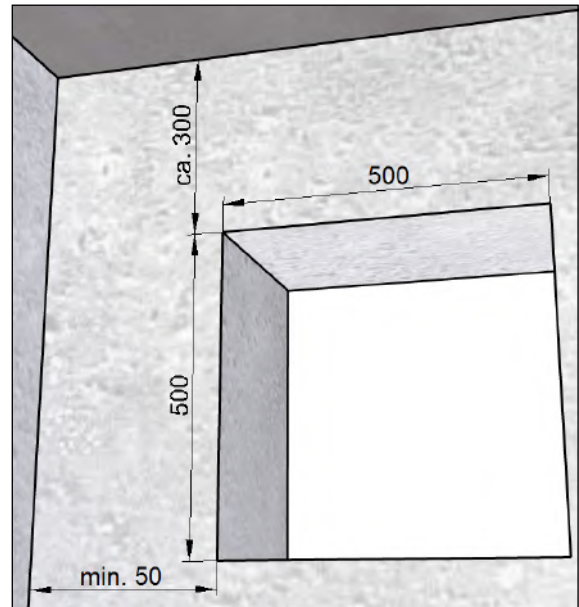

Fig. 9: Wall breakthrough for installation kit **with** filler piece, dimensions in millimetres

#### 9.1.1 Planning the wall breakthrough for new builds

- Commission an architect or design professional to include the wall breakthrough at a suitable point in the construction drawing and execute it when constructing the building shell.

There are two possible versions of the wall breakthrough:

- Wall breakthrough with recess (see Fig. 8) for installation kit **without** filler piece M-WRG-M/Fü
- Complete wall breakthrough (see Fig. 9) for installation kit **with** filler piece M-WRG-M/Fü

## 9.1.2 Breaking through an existing wall

### **⚠ WARNING**

#### **Danger due to damaging supply lines and changing the stress loadings**

- ▶ Make sure that there are no supply lines in the vicinity of the wall breakthrough (e.g. power, gas or water).
- ▶ Make sure that the wall breakthrough does not affect the local static loading requirements.
- ▶ Fit a lintel if necessary.

- ▶ Break through the wall. There are two possible versions of the wall breakthrough:
  - Wall breakthrough with recess (see Fig. 8 on page 17) for installation kit **without** filler piece M-WRG-M/Fü
  - Complete wall breakthrough (see Fig. 9 auf page 17) for installation kit **with** filler piece M-WRG-M/Fü

## 9.2 Chasing out channels for connecting cables

- ▶ Chase one channel for the mains cable (item 1 in Fig. 10) and one for the control cable, if required (item 3 in Fig. 10).

### **NOTICE**

- A separate channel is needed for the control cable.
- The wall channels in Fig. 10 are shown by way of example. Alternative wall channels are shown as dashed lines (item 2 and item 4 in Fig. 10). For the subsequent electrical installation work, we recommend running the mains cable from the left and the control cable (if used) from the right at the wall breakthrough.

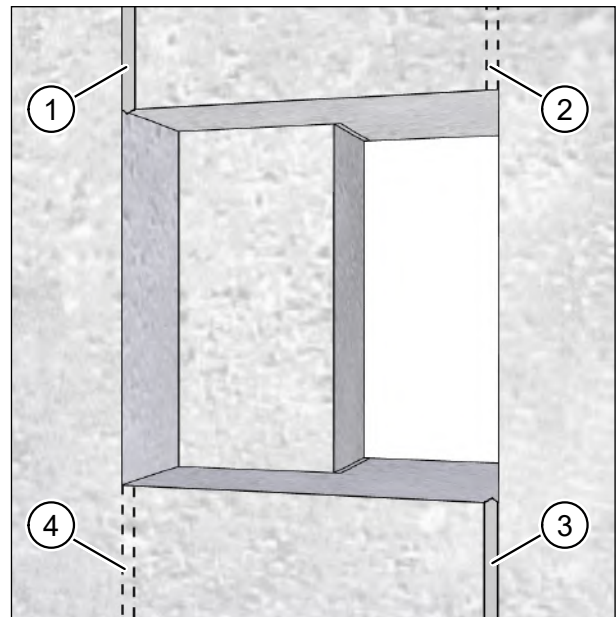

Fig. 10: Chasing out channels for connecting cables

### 9.3 Running the mains and control cables

#### **⚠ DANGER**

##### **Potentially fatal voltages**

- The electrical installation work must only be carried out by a qualified electrician.
- The VDE regulations or any special safety regulations applicable in your country apply to the electrical installation work.
- ▶ Before starting installation or maintenance work, disconnect the mains cable for connecting to the ventilation unit on all poles from the mains supply.
- ▶ Observe the five safety rules (DIN VDE 0105-100, EN 50110-1) for working on electrical systems:
  - Disconnect from mains (all-pole disconnection of a system from live parts)
  - Secure against reconnection
  - Check that the system is voltage-free
  - Earth and short-circuit
  - Cover or block off access to adjacent live parts

- ▶ Run the mains cable (item 1 in Fig. 11) and the control cable, if required (item 2 in Fig. 11). The cables should extend roughly 250 mm beyond the wall.
- ▶ Fix the mains cable and the control cable (if used) in position.

#### **NOTICE**

- Table 2 on page 20 contains an overview of the recommended types of mains cable and control cable.
- A control cable is only needed for certain types of ventilation unit.
- The ventilation unit is equipped with an external control input as standard. The mains cable **NYM-J 4x1.5 mm<sup>2</sup>** is needed if this control input is used.

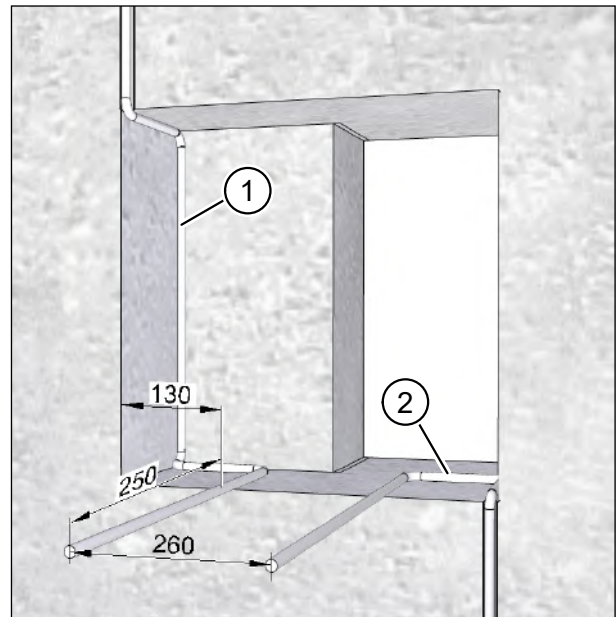

Fig. 11: Running the connecting cables, dimensions in millimetres

### 9.3.1 Cable types

Part no.	Type of ventilation unit	Type of mains cable	Type of control cable
5010 (*)	M-WRG-S	NYM-J 3x1.5 mm <sup>2</sup> or NYM-J 4x1.5 mm <sup>2</sup> (**)	No control cable
5016-1-0	M-WRG-S/Z-S	NYM-J 3x1.5 mm <sup>2</sup> or NYM-J 4x1.5 mm <sup>2</sup> (**)	J-Y (St) Y 4 x 2 x 0.6 mm / J-Y (St) Y 4 x 2 x 0.8 mm
5016-1-1 5016-1-1-1 5016-1-1-2	M-WRG-S/Z-T M-WRG-S/Z-T-F M-WRG-S/Z-T-FC	NYM-J 3x1.5 mm <sup>2</sup> or NYM-J 4x1.5 mm <sup>2</sup> (**)	J-Y (St) Y 10x2x0.6 mm / J-Y (St) Y 10x2x0.8 mm
5012 5012-1 5012-2	M-WRG-S M M-WRG-S M-F M-WRG-S M-FC	NYM-J 3x1.5 mm <sup>2</sup> or NYM-J 4x1.5 mm <sup>2</sup> (**)	Building management system, Modbus, Loxone, KNX: J-Y (St) Y 2x2x0.6 mm / J-Y (St) Y 2x2x0.8 mm
5013 5014-1 5014-2	M-WRG-S 485 M-WRG-S 485-TF M-WRG-S 485-TFC	NYM-J 3x1.5 mm <sup>2</sup> or NYM-J 4x1.5 mm <sup>2</sup> (**)	Touch Control network: J-Y (St) Y 2x2x0.6 mm / J-Y (St) Y 2x2x0.8 mm

Table 2: Types of mains cable and control cable for each ventilation unit type

(\*) If you install this type of ventilation unit in the M-WRG-M/MB-U<sup>2</sup> installation kit, we recommend that you use the following options to operate the ventilation units:

- Using the app via the gateway M-WRG-GW, part no. 5453-00
- Wireless remote control M-WRG-FBH, part no. 5478-10
- 4-way wireless pushbutton switch M-WRG-FT, part no. 5478-20
- External wireless humidity sensor M-WRG-II FSF, part no. 733010
- External wireless CO<sub>2</sub> sensor M-WRG-II FSC, part no. 733011

(\*\*) If the external control input is used

### 9.3.2 External control input

With the external control input supplied as standard, the M-WRG unit has an additional input terminal for 230 V AC (working voltage range: 85 V AC to 265 V AC / 50 - 60 Hz) to which a switch, time switch, motion detector or similar may be connected.

The external control input is equipped with a time-delay relay that can be used to set a switch-on delay and a run-on time:

- Switch-on delay: the M-WRG unit does not start until the set time has elapsed.
- Run-on time: the M-WRG unit does not switch to the previously active ventilation program until the set time has elapsed.

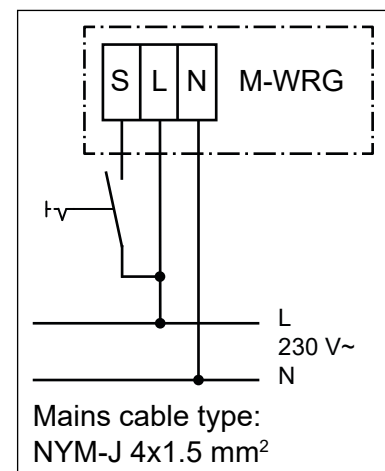

Fig. 12: Connection diagram for external control input

In addition, the following options are available for the external control input supplied as standard:

- M-WRG-O/EST-1 (without switch-on delay, part no. 5046-31)
- M-WRG-O/EST-2 (without run-on time, part no. 5046-32)

Windowless rooms can be ventilated in accordance with DIN 18017-3 in combination with the M-WRG-O/NOF option (part no. 5046-10).

## 9.4 Inserting the wall box

### NOTICE

- ▶ Prepare the breakthrough surfaces suitably for the wall box.
- ▶ Remove the plaster cover (item 1 in Fig. 13) from the wall box (item 5 in Fig. 13).
- ▶ Remove the cardboard insert (item 2 in Fig. 13) from the wall box (item 5 in Fig. 13).
- ▶ Thread the mains cable (item 3 in Fig. 13) through the cable inlet A (item A in Fig. 13) in the wall box.

### NOTICE

Cable inlet B for the control cable is sealed when the unit is supplied.

- ▶ If necessary, use a screwdriver to punch through the sealed cable inlet B (item B in Fig. 13).
- ▶ Thread the control cable, if required (item 4 in Fig. 13) through the cable inlet B (item B in Fig. 13) in the wall box.
- ▶ Push the wall box (item 5 in Fig. 13) fully into the wall breakthrough.

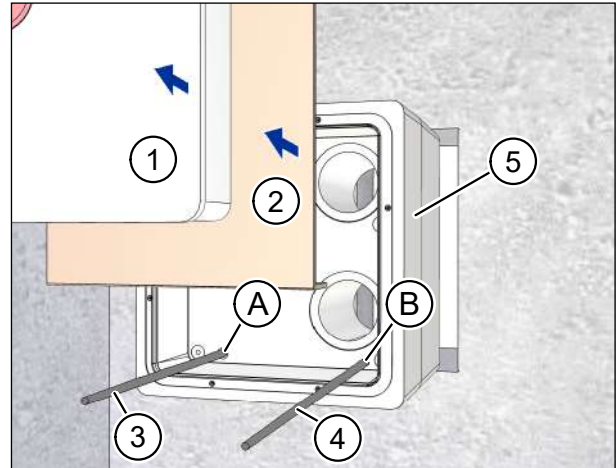

Fig. 13: Inserting the wall box

## 9.5 Inserting the cardboard insert and plaster cover

- ▶ Insert the cardboard insert (item 1 in Fig. 14) into the wall box (item 4 in Fig. 14) as far as it will go.
- ▶ Insert the plaster cover (item 2 in Fig. 14) into the wall box (item 4 in Fig. 14) as far as it will go.

### NOTICE

When the gaps around the wall box are filled with foam (see section 9.7 on page 23), there is a risk that the wall box will be deformed by the pressure of the foam if the plaster cover is not inserted. If this happens, it will not be possible to insert the ventilation unit into the wall box.

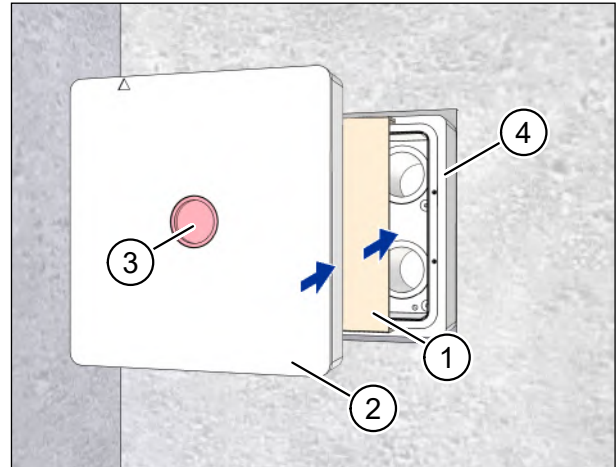

Fig. 14: Inserting the cardboard insert and plaster cover

- ▶ Check that the red signal cover (item 3 in Fig. 14) is seated in the plaster cover.

## 9.6 Fixing the wall box

- ▶ Fix the wall box (item 1 in Fig. 15) in position in the wall breakthrough using wedges or air cushions (item 2 in Fig. 15) on both the inside and the outside.
- ▶ Use the spirit level (item 3 in Fig. 15) to align the wall box so that it is perpendicular and flush with the wall.

### NOTICE

- ▶ Make sure that the wall box is perpendicular as this is the only way to ensure that any condensation will be carried outside by the 2° pipe fall.
- ▶ Fix the filler piece, if needed, to the external wall with wedges or air cushions.

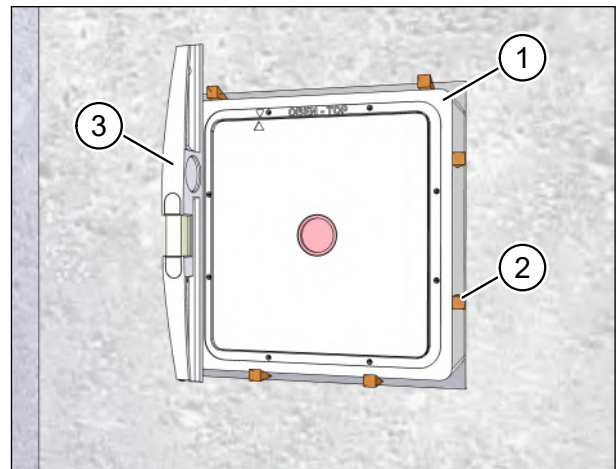

Fig. 15: Fixing the wall box

### NOTICE

The plastering trim is 15 mm deep (see Fig. 16).

- ▶ If the depth of plaster should be more than 15 mm, position the wall box so that it protrudes sufficiently out of the solid wall. If you do not do this, there is a risk that the ventilation unit will not work correctly.
- ▶ If the interior wall is not perpendicular or flat, align the front surface of the plastering trim (item 1 in Fig. 16) parallel to a plaster stop bead running vertically.

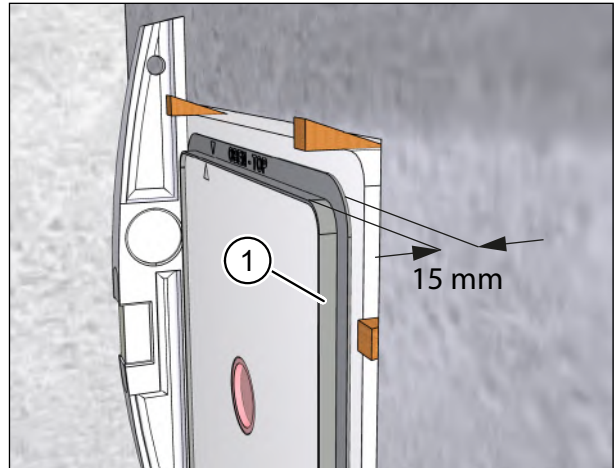

Fig. 16: Depth of plastering trim 15 mm

## 9.7 Filling gaps around the wall box with foam

### NOTICE

- ▶ Check that the plaster cover (item 2 in Fig. 14 on page 22) is inserted before filling with foam.
- ▶ Check that the wall box is seated correctly. Once you have used the foam, you will not be able to align it further.
- ▶ Fill the gaps between the wall box and wall breakthrough all around and continuously with expanding foam (item 1 in Fig. 17) or using another suitable filling material.
- ▶ Once the foam has hardened, remove any wedges that extend beyond the solid wall.

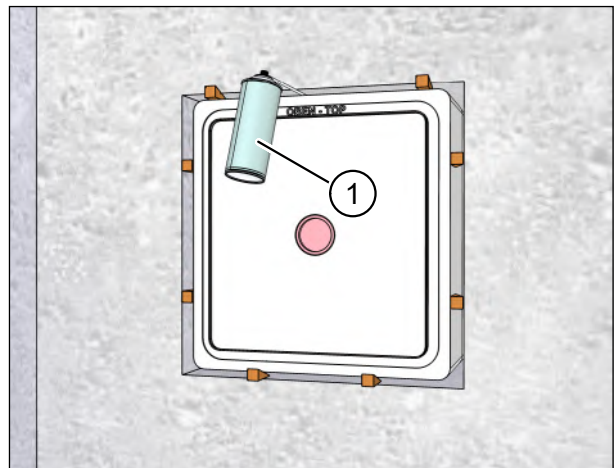

Fig. 17: Filling gaps around the wall box with foam

## 9.8 Condensate drain on the exhaust air pipe

If M-WRG ventilation units are used, a condensate drain should be provided under certain circumstances (see section 2.2.4 on page 8). The M-WRG-II LR 50-KA set, part no. 735200, with the following components may be used for this purpose:

- Outdoor air pipe, DN 100, 0.5 m (item 1 in Fig. 18)
- Exhaust air pipe, DN 100, 0.5 m (item 2 in Fig. 18), with 1/2" male thread connection (item 3 in Fig. 18) and barrier (item 4 in Fig. 18) for retaining the condensate.

### NOTICE

Note the following points when creating the condensate connection:

- The condensate drain is to be created by the customer.
- Prevent odour transfer by installing an odour trap.
- If possible, connect the condensate drain to a grey water or rainwater discharge.
- In cold regions, protect the condensate drain pipe (item 5 in Fig. 18) against frost, e.g. by running it behind the facade insulation.

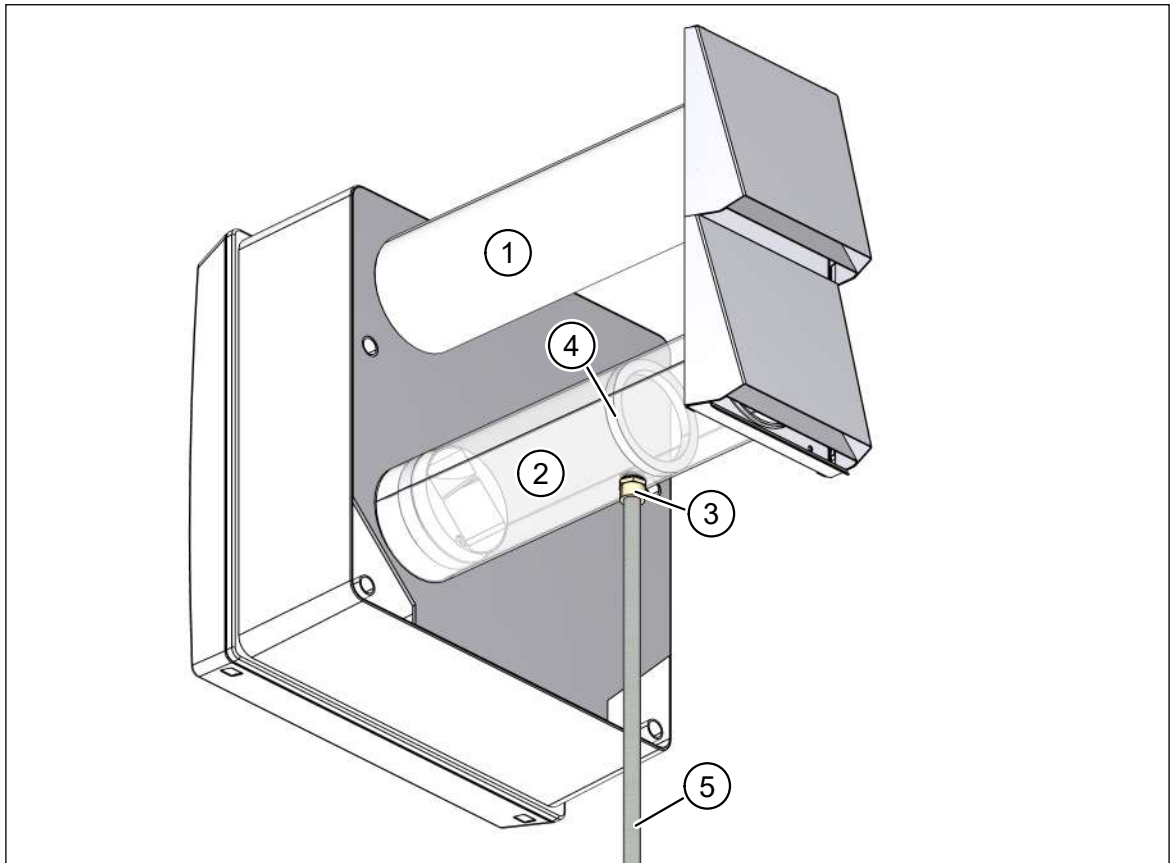

Fig. 18: Condensate drain on the exhaust air pipe



## 9.9 Plastering the installation kit on the inside

### NOTICE

- ▶ Prepare the substrate suitably before plastering.
- ▶ Make sure that the signal cover (item 1 in Fig. 19) is seated in the plaster cover (item 2 in Fig. 19).
- ▶ Cut off any excess expanding foam on the wall box.
- ▶ Apply the plaster scrim M-WRG-PG (item 3 in Fig. 19) to the installation kit and the solid wall.

### NOTICE

Applying plaster scrim will minimise subsequent cracking of the plaster.

- ▶ Plaster the internal wall. The plaster forms the airtight layer on the internal wall. The expanding foam does not act as an airtight layer.
- ▶ When plastering, make sure that the plaster ends flush with the plastering trim. The following situations are not permitted:
  - The plastering trim (item 1 in Fig. 20) protrudes above the plaster (item 2 in Fig. 20).
  - The plaster (item 2 in Fig. 21) protrudes above the plastering trim (item 1 in Fig. 21).

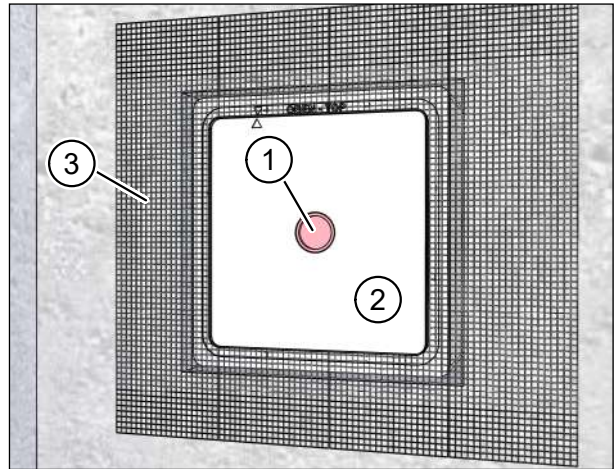

Fig. 19: Plastering the installation kit on the inside

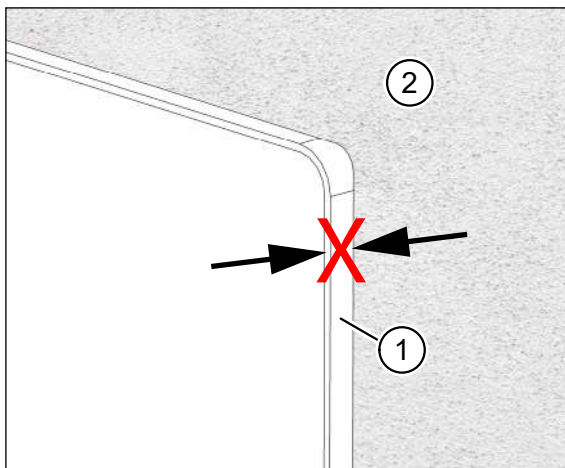

Fig. 20: Plastering trim protrudes over plaster

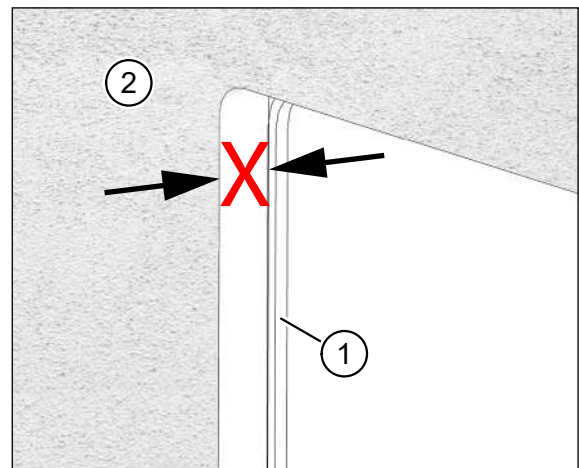

Fig. 21: Plaster protrudes over plastering trim

## 9.10 Aligning the wall box on the outside before plastering

- ▶ Fill the gaps between the wall box and wall breakthrough all around and continuously with expanding foam or using another suitable filling material.

### 9.10.1 If the solid wall is less than 36.5 cm thick

- ▶ Use a Styrofoam saw to cut off the excess wall box (item 1 in Fig. 22 and Fig. 23) and filler piece, if necessary (item 2 in Fig. 23), so that they are flush with the solid wall or any insulation.

#### NOTICE

The wall box fixes the ventilation pipes with a 2° fall to the external wall.

- ▶ If the unplastered wall is thin (24 cm or less), do not cut off the wall box flush with the unplastered wall. Allow the wall box to protrude into the external thermal insulation composite system (ETICS) as this is the only way to allow the ventilation pipes to pass far enough through and so be fixed in place.
- ▶ When fitting the ETICS, make sure that the ventilation pipes maintain their 2° fall.

### 9.10.2 If the solid wall is more than 36.5 cm thick

- ▶ Compensate for thicker walls with continuous pipes. For walls that are 60 cm thick or more, you will need 100 cm long outdoor and exhaust air pipes (M-WRG-LR 100, part no. 5580).

#### NOTICE

The pipes must be continuous. Pipes that have been joined must not be used as there is a risk of allowing condensation to penetrate the masonry.

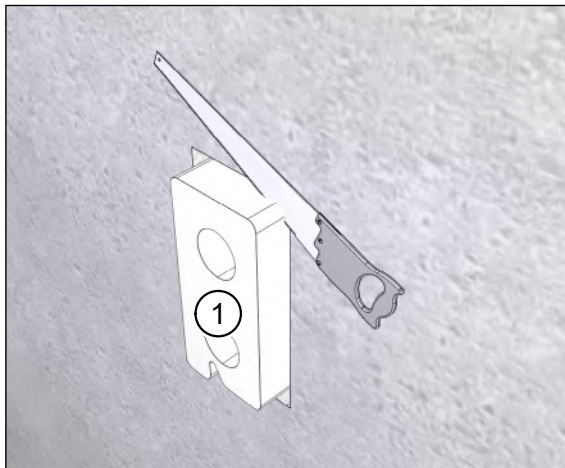

Fig. 22: Aligning the wall box **without** filler piece

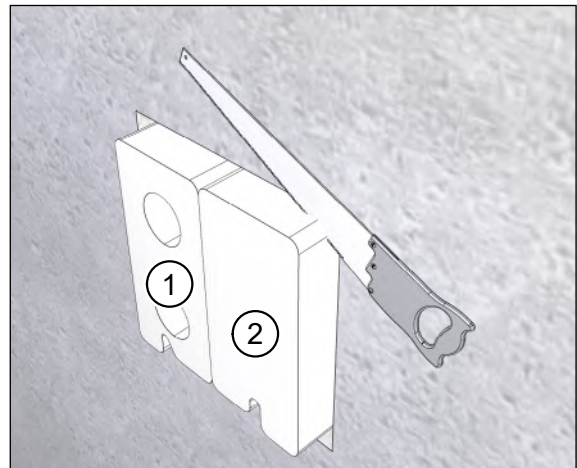

Fig. 23: Aligning the wall box **with** filler piece

## 9.11 Plastering the installation kit on the outside

- ▶ Insert the protective sleeves (item 1 in Fig. 24 and Fig. 25). They should extend beyond the solid wall so that they will end flush with the subsequent plaster coat. The protective sleeves provide the bonding surface for the external plaster.

### NOTICE

- ▶ Prepare the substrate suitably before plastering.
- ▶ Apply the plaster scrim (item 2 in Fig. 24 and Fig. 25) to the outside of the wall box, to the masonry and to the facade insulation.

### NOTICE

Applying plaster scrim will minimise subsequent cracking of the plaster.

- ▶ Plaster the external wall. The plaster forms the windtight layer on the external wall.

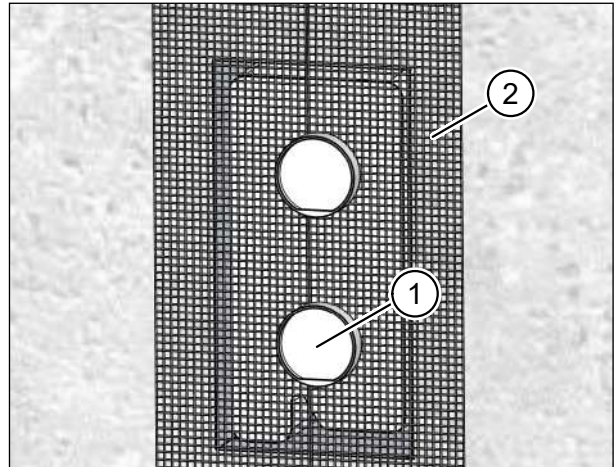

Fig. 24: Plastering the installation kit **without** filler piece

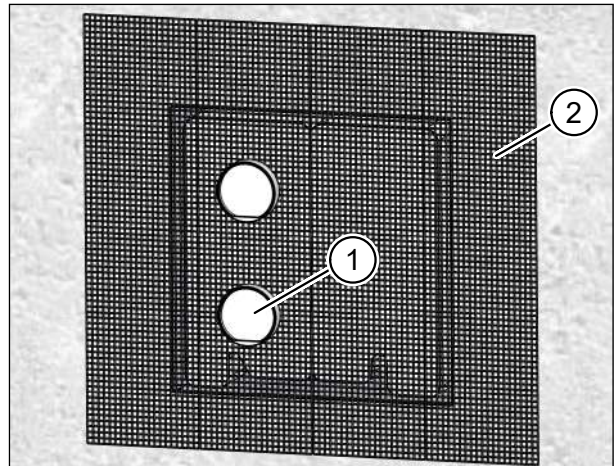

Fig. 25: Plastering the installation kit **with** filler piece

## 9.12 Preparing the installation kit for connecting the ventilation pipes

- Work on the internal wall:
  - ▶ Remove the signal cover (item 1 in Fig. 26).
  - ▶ Use a blade to score the plaster on the inside of the plastering trim (item 2 in Fig. 26).
  - ▶ Carefully remove the plaster cover (item 3 in Fig. 26) and the cardboard insert behind it.
- Work on the external wall:
  - ▶ Remove the two protective sleeves (item 1 in Fig. 27).

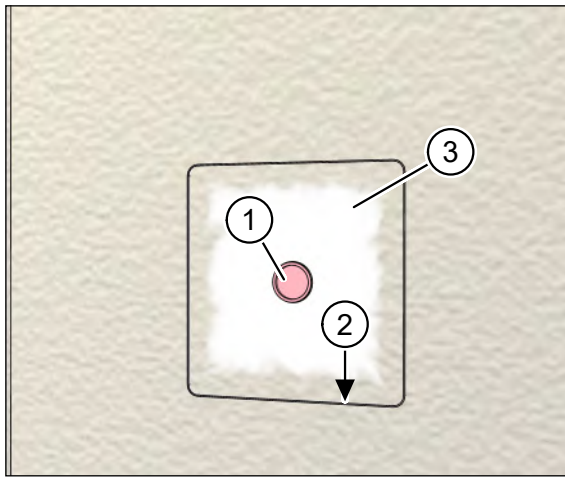

Fig. 26: Installation kit plastered on the inside

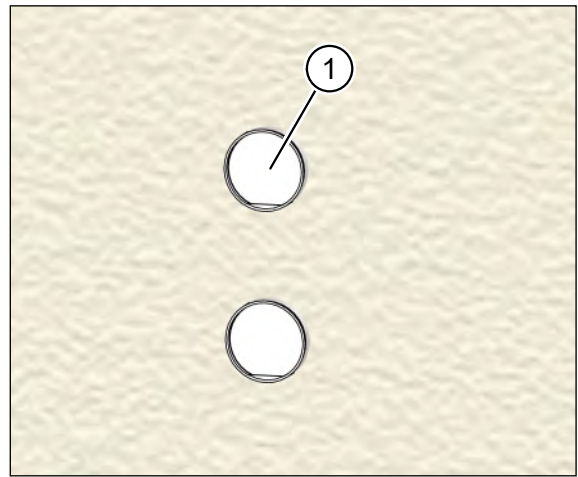

Fig. 27: Installation kit plastered on the outside

## 9.13 Cutting ventilation pipes to length

- ▶ Push the two ventilation pipes (item 1 in Fig. 28) into the openings in the installation kit until they end flush with the inside of the installation kit (item 2 in Fig. 28).
- ▶ On the outer wall, mark the required excess length of the ventilation pipes to suit the outer wall terminal, see Table 3.
- ▶ Remove the ventilation pipes from the openings in the installation kit.
- ▶ Shorten the ventilation pipes to the marked length.
- ▶ Deburr the inner and outer ends of the ventilation pipes.

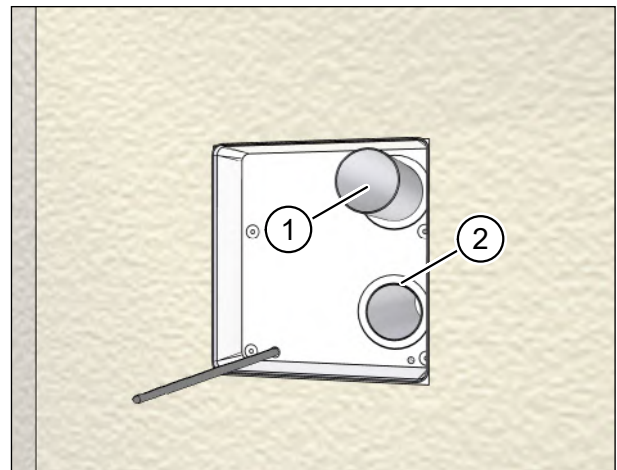

Fig. 28: Cutting ventilation pipes to length

## NOTICE

If you do not deburr the ventilation pipes there is a risk of damaging the seals at the ventilation unit and outer wall terminal.

Outer wall terminal	Excess length
Stainless steel pod, M-WRG-ES...	5 - 10 mm from the plastered external wall
Plastic pipe set, M-WRG-II KSR...	20 - 27 mm from the plastered external wall

Table 3: Excess length of ventilation pipes protruding from the external wall

### 9.14 Inserting and fixing the ventilation pipes

- ▶ Apply permanently elastic sealant to the outer skin of the ventilation pipes (item 1 in Fig. 29).
- ▶ Push the ventilation pipes back into the openings in the installation kit.
- ▶ Using a twisting motion, push the two ventilation pipes into the openings in the installation kit until they end flush with the inside of the installation kit (item 2 in Fig. 29).
- ▶ Remove any excess sealant.

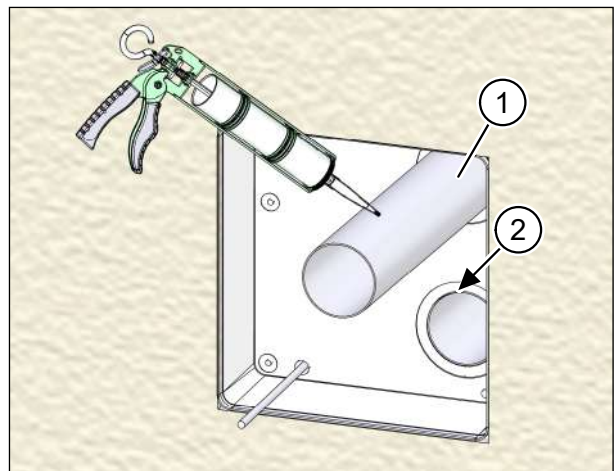

Fig. 29: Inserting and fixing the ventilation pipes

### 9.15 Sealing ventilation pipes on external wall

## NOTICE

If the external plaster encloses the ventilation pipes all round and without gaps, you can skip the steps described in this section.

- ▶ Chamfer both pipe breakthrough edges (item 1 in Fig. 30) to roughly 5 x 45° to create enough space for the sealing joints with permanently elastic sealant.
- ▶ Fill the chamfers of the pipe breakthrough edges all-round with permanently elastic sealant on the outside.

## NOTICE

Only use a solvent-free sealant if the sealant is applied to polystyrene.

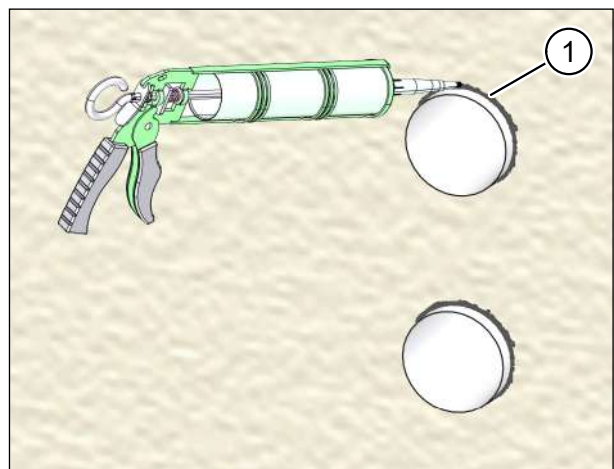

Fig. 30: Sealing ventilation pipes on the external wall

## 9.16 Attaching the outer wall terminal

### **⚠ WARNING**

**Do not run without the outer wall terminal.**

- ▶ Please note that the ventilation unit must not be used without the outer wall terminal for safety reasons.
- ▶ Attach the outer wall terminal to the external wall.

### **NOTICE**

Installation of the outer wall terminal is described in a separate installation manual (see “1.8 Supplementary documents” on page 6).



Fig. 31: Attaching the outer wall terminal (example stainless steel ventilation pod, M-WRG-ES)

## 10 Installing the ventilation unit

### **NOTICE**

Installation of the ventilation unit in the installation kit is described in a separate installation manual (see “1.8 Supplementary documents” on page 6).



Fig. 32: Ventilation unit installed



We have checked the content of this publication for conformity with the product described in it. There may nevertheless still be differences, so we cannot guarantee complete accuracy.

The information in this publication is regularly checked and any necessary corrections are made in subsequent editions.

Copyright © Meltem Wärmerückgewinnung GmbH & Co. KG

We reserve the right to make changes.

---

**Meltem Wärmerückgewinnung GmbH & Co. KG**

Am Hartholz 4

D-82239 Alling

Germany

Tel. +49 8141 404179-0

Fax +49 8141 404179-9

Internet: [www.meltem.com](http://www.meltem.com)

Email: [info@meltem.com](mailto:info@meltem.com)



Go to  
Meltem download area